

# Rectangular Attenuators and Splitters

Type DS · DK

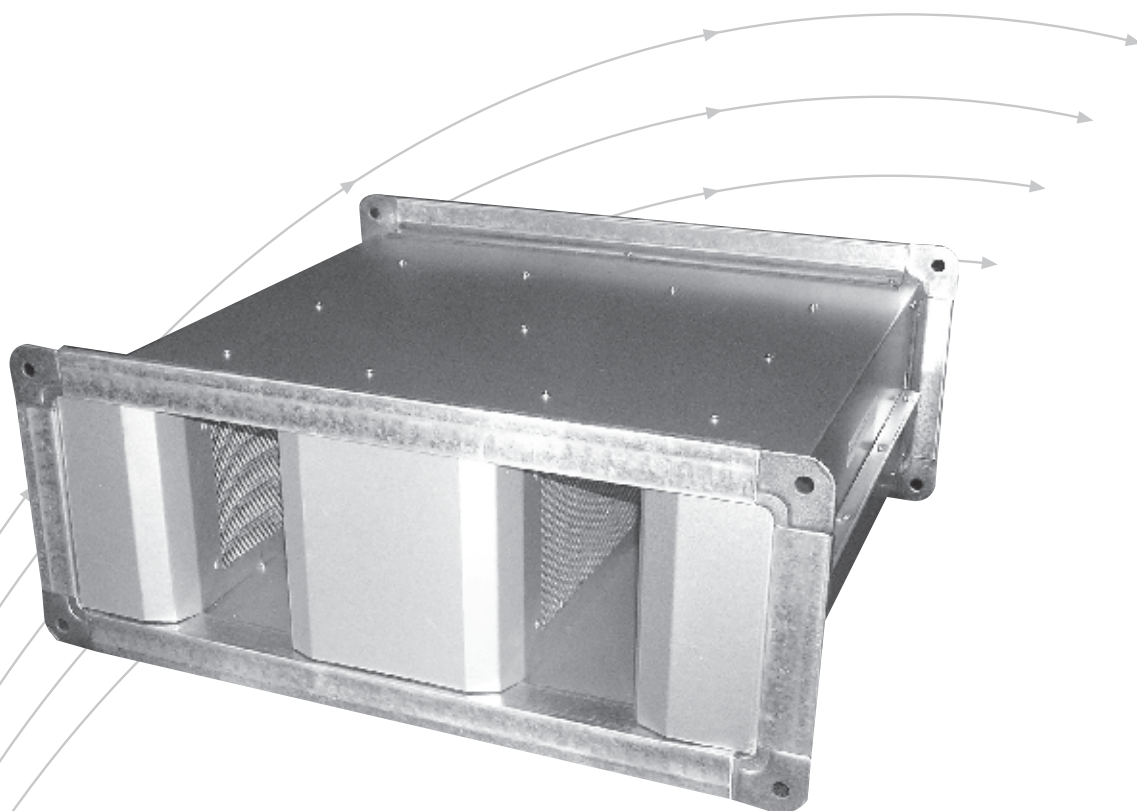

**TROX<sup>®</sup> TECHNIK**

TROX Malaysia Sdn. Bhd.  
20 Persiaran Bunga Tanjung 1  
Senawang Land Industrial Park  
70400 Seremban  
Negeri Sembilan Darul Khusus  
Malaysia

Telephone + 606-678 8188  
Telefax + 606-678 8288 / 388  
E-mail enquiry@troxapo.com  
www.troxapo.com

# Contents · Description

Description _____	2	Attenuator Performance _____	7
Dimensions · Construction _____	3	Quick Selection Method _____	8
Bend attenuators _____	4	Full Selection Method _____	9
Flangeless Construction _____	5	Aerodynamic Data _____	10
Weights _____	6	Order Details _____	14

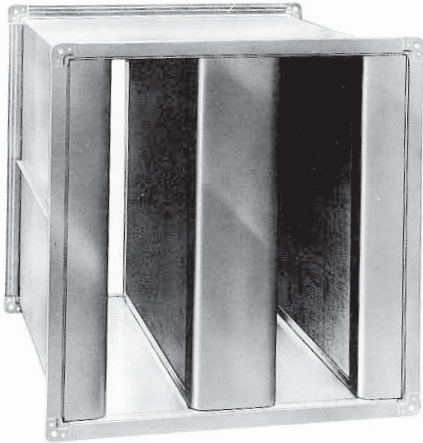

The aerodynamic and acoustic performance data as published in this catalogue for the Type 'DS' attenuator and Type 'DK' splitter have been tested to the British Standard, BS 4718\*.

The casing construction for Type 'DS' attenuator complies with DW/ 144, the UK's specification for sheet metal ductwork. The infill acoustic absorption material for both 'DS' and 'DK' has been successfully tested to the British Standard, BS 476 Parts 6 and 7 and, complies with the Class 'O' Building Regulations for fire safety requirements. The 'DK' splitters was successfully tested by Warrington Fire Research Centre at 250°C for 120 minutes (or 2 hours) for structural integrity and, for ignitability, spread of flame and release of heat and smoke to AZ/NZ Standard 1530.3.

The infill material was successfully tested against fibre erosion with air velocity for up to 30 m/s in the airway. The exposed face of the infill material is protected by galvanized perforated sheet steel.

Both 'DS' and 'DK' are capable of withstanding high temperature and, were tested independently at 250°C for 2 hours.

If preferred, Type 'DK' splitters can be supplied for inclusion in air handling units or builder's work duct. Airway space channels for installing the 'DK' splitters can be supplied as optional extras.

## \*Reference:

British Standard, BS 4718 – 'Methods of test for silencers for air distribution systems.'

## \* What is Melinex?

Melinex is a polyester film with high tensile strength and is resistant to tearing, temperature, and attack by most common chemicals and solvents, without severely affecting its acoustic performance.

## Applications

This is used as a protective layer for mineral fibre insulation in air conditioning systems for the purpose of either sound absorption or thermal insulation. This is because it is resistant to attack by chemicals and/or solvents.

## Benefits

- Acoustically permeable
- Highly resistant to many chemicals, solvents, fire and water vapour
- Excellent containment medium for glass and mineral fibres
- Resilient to tearing
- No special adhesive is required

## Construction

The Type 'DS' attenuators and Type 'DK' splitters are manufactured from 1mm thick galvanized sheet steel. The attenuator casings are formed with either stand-up or lock formed joints with mastic sealant in accordance to U.K.'s standards for sheet metal ductwork, DW/144. 40 mm Doby flanges will be provided with the Type 'DS' attenuators as standard supply.

The acoustic infill material complies with Class 'O' of the U.K.'s Building Regulations. It has a protective glass tissue face to prevent fibre erosion and, is also protected by a expanded metal sheet against mechanical damage. The acoustic infill material has been tested successfully against fibre erosion for up to 30 m/s airway velocity. The splitters have bull-nose at each end of the splitter to minimise air pressure drop and regenerated noise. The splitters in the 'DS' attenuators are installed vertically in relationship to the floor.

This attenuator is available only in the following standard lengths in millimeters (mm);

600; 900; 1200; 1500; 1800 and 2100 mm.

**NOTE:** A combination of a splitter and one airway is considered as one 'module'. The first 'module' will always be half the width of a standard splitter (i.e.,  $d/2$ ), which will be located at both ends of the casing width (B). The standard width of a splitter is represented by 'd'. Refer to the diagram for Type 'DS' below.

## Alternative Constructions

Type '**DSL**' – Construction as per 'DS' except the overall silencer length is 150 mm longer (i.e.,  $L + 150$  mm). This includes 'evase fairing' to further reduce the pressure loss across the silencer.

Type '**DSZ**' – Construction as per 'DS' except that splitters are installed horizontally.

Type '**DSH**' – Construction as per 'DS' except that the casing is made from 1.2 mm thk. galvanised steel, suitable for medium and high pressure systems.

Type '**DSM**' – Construction as per 'DS' with an additional \*Melinex (refer to page 2 for detail) is applied over the infill material.

Type '**DSB**' – Construction as per 'DS' with a 90° vertical bend.

Type '**DSBZ**' - Construction as per 'DS' with a 90° horizontal bend.

Type '**DSR**' - Construction as per 'DS' with RSA flange connections.

## Modular Construction

The Type 'DS' attenuators will be supplied in modular sections if any one of the dimensions for the overall attenuator size exceeds the following;

$B = 2100$  mm;  $H = 1800$  mm and  $L = 2100$  mm

The modular sections of the attenuators will be supplied as 'loose items' to site to be installed by others. Full details of the attenuator configuration will be provided by TROX to the customer once the order is confirmed.

**Attenuator Type DS**

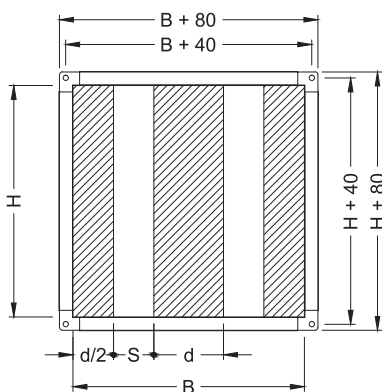

**Splitter Type DK**

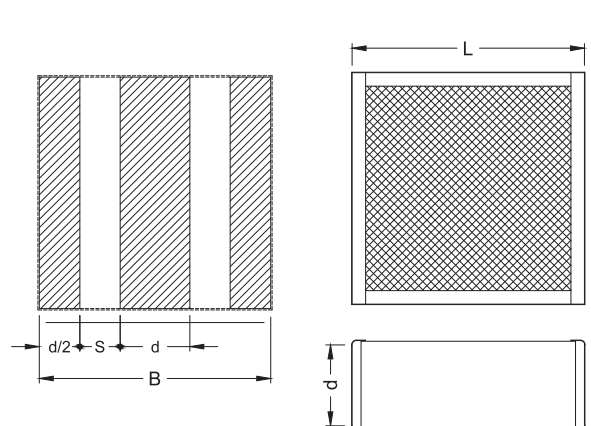

B - Duct width  
H - Duct Height  
S - Air Gap  
d - Splitter width

\*Refer to NOTE on page 2 of this catalogue for information on 'Melinex'.

# Bend Attenuators

## Bend Attenuators

The construction specification for the cased bend attenuators is similar to the Type 'DS' except for turning vanes, which are incorporated into the bend attenuators to minimise the pressure drop across them.

The dimension 'L' as shown in the diagram below denotes the bend centre path length, which equates to the acoustic length referred to in the selection tables in this catalogue.

Dimensions L1 and L2 as shown in the diagrams below, refer to the air entry and discharge legs respectively, measured along the external length (i.e., outside) of the bend. Unless specifically requested by the customer in writing, the standard bend attenuators will be supplied with equal lengths for L1 and L2.

Bend attenuators can be designed for vertical or horizontal installation as shown below to suit ductwork layout.

### NOTE:

Customer should clearly state if a vertical or horizontal installation is required at enquiry stage since their construction are different and, are NOT inter-changeable.

### Vertical Bend Attenuator Type DSB

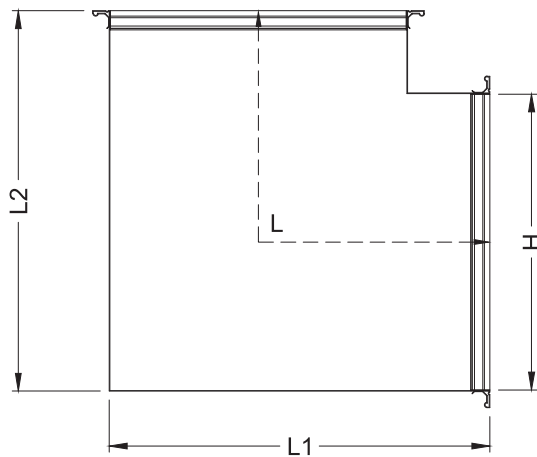

### Horizontal Bend Attenuator Type DSBZ

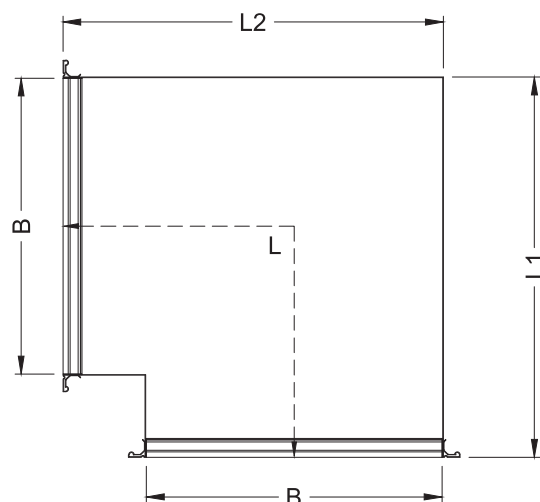
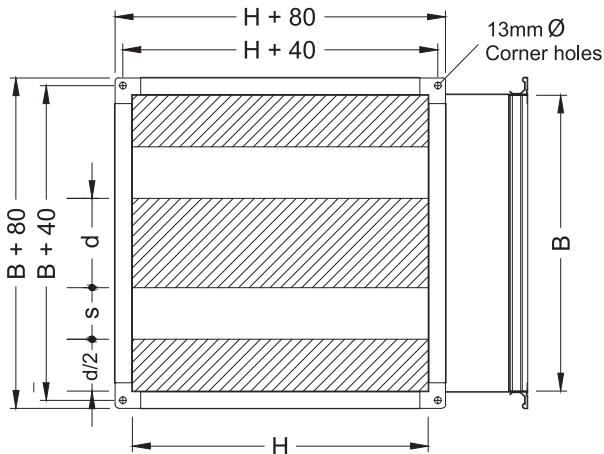
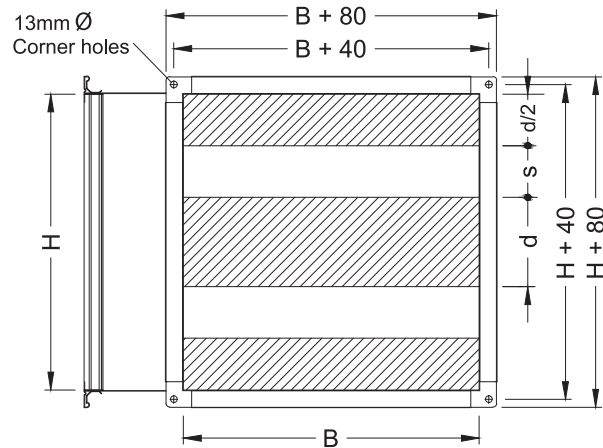

# Flangeless Construction

## Flangeless Construction

For smaller ducts, attenuators can be supplied with spigot connections. DW 144 specification for sheet metal ductwork recommends that the maximum duct size for such spigot joint should be limited to 400 mm wide by 400 mm high.

Attenuator Type DSZS

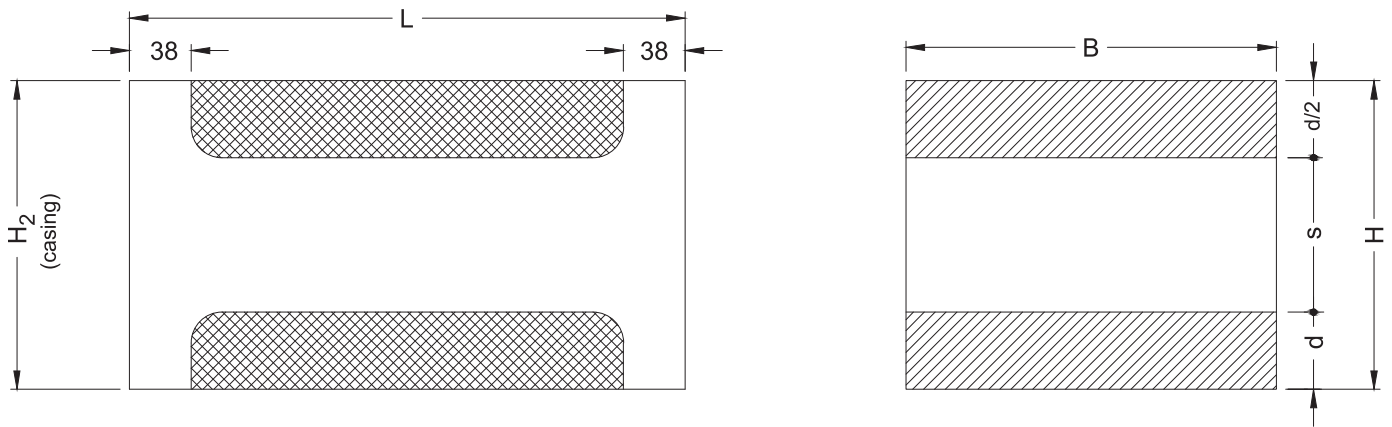

Attenuator Type DSZSX

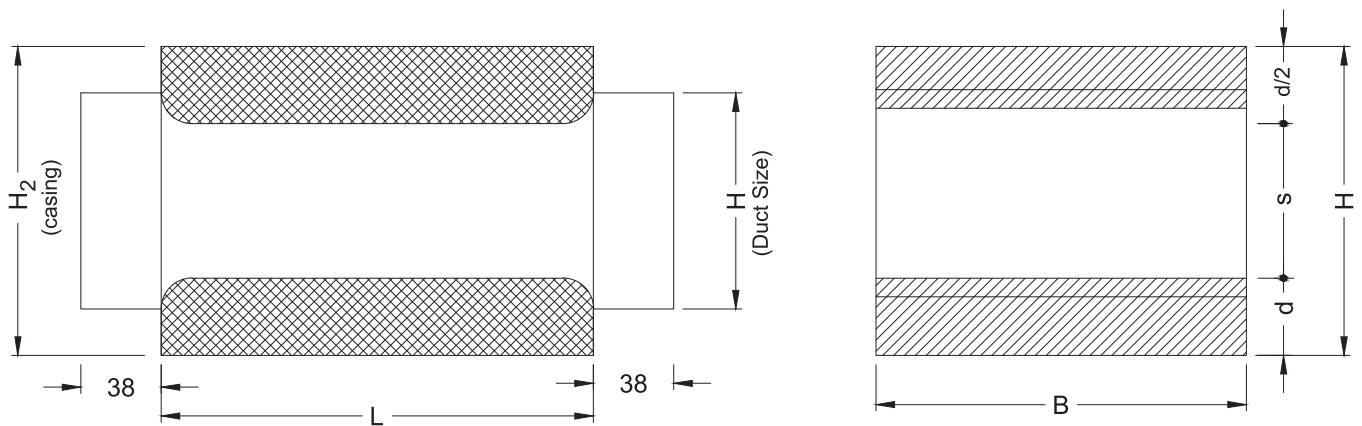

# Weights

**Table 1: Weight of DS20 Cased Attenuator**

Width B in mm	DS20-75	275	550	825	1100	1325	1650	1925
	DS20-100	300	600	900	1200	1500	1800	2100
Number of modules	DS20-150	350	700	1050	1400	1750	2100	-
	DS20-200	400	800	1200	1600	2000	-	-
Length L in mm	Height H in mm	Weight, kg ±10%						
600	300	16	26	36	46	56	64	70
	600	23	36	49	62	75	87	95
	900	30	46	62	78	94	110	120
	1200	37	56	75	93	113	132	145
	1500	-	66	82	110	131	153	169
	1800	-	-	106	132	159	185	205
900	300	22	36	49	63	77	90	98
	600	31	49	66	84	102	119	130
	900	41	63	84	106	128	150	164
	1200	50	76	101	127	153	179	197
	1500	-	90	116	148	178	207	229
	1800	-	-	144	180	216	252	280
1200	300	26	44	61	79	97	115	123
	600	38	60	82	104	127	149	162
	900	50	78	106	133	161	189	207
	1200	63	95	127	160	192	225	248
	1500	-	113	149	186	224	261	289
	1800	-	-	182	227	273	319	355
1500	300	30	51	72	92	113	134	144
	600	44	70	96	121	147	173	188
	900	58	90	122	154	186	218	239
	1200	72	110	147	185	222	259	286
	1500	-	130	172	215	258	301	333
	1800	-	-	210	262	315	368	409
1800	300	42	70	95	122	150	176	193
	600	60	96	130	165	201	235	256
	900	80	124	166	208	252	297	325
	1200	98	150	199	250	301	355	390
	1500	-	178	230	293	351	411	454
	1800	-	-	284	355	427	500	554
2100	300	46	78	108	140	172	203	219
	600	67	107	146	186	227	265	290
	900	89	138	187	236	286	335	365
	1200	110	167	225	284	340	400	440
	1500	-	200	261	330	398	464	513
	1800	-	-	322	401	485	565	629

**Table 2: Weight of DK20 Splitters**

Width in Modules		One Module	Each additional Module
Length L in mm	Height H in mm	Weight, kg ±10%	
600	300	6	5
	600	10	8
	900	14	10
	1200	17	13
	1500	20	15
900	1800	27	17
	300	9	7
	600	14	10
	900	20	14
	1200	25	18
1200	1500	30	21
	1800	39	25
	300	11	8
	600	17	13
	900	25	18
1500	1200	34	23
	1500	42	27
	1800	55	31
	300	13	10
	600	21	16
1800	900	30	22
	1200	34	28
	1500	51	32
	1800	66	38
	300	17	11
2100	600	28	19
	900	39	25
	1200	55	32
	1500	66	37
	1800	78	45
300	300	19	13
	600	30	19
	900	44	28
	1200	61	35
	1500	75	44
600	1800	88	52

**NOTE:**

It should be noted that:

- a. Attenuator will be supplied in modular sections, if B > 2100 mm; H > 1800 mm and/or L > 2100 mm.
- b. If a unit is larger all of the unit sizes given in the table above, its total weight can be calculated by adding up the weight of all the modular sections for that attenuator.

# Attenuator Performance · Design Criteria

## Attenuator Performance

The acoustic and aerodynamic performance data for the Type 'DS' attenuator is derived from testing this product to the British Standard, BS 4718. The static insertion loss data is given in Table 4 on page 9 of this catalogue. The same performance data can be applied to the Type 'DK' splitters provided they are installed correctly to TROX recommendations.

Regenerated noise data is given in this catalogue on Table 2 to allow Installed Insertion Loss to be calculated. This table should only serve as a guide to determine what should be the permissible maximum air velocity through the attenuator in order to achieve the required design noise level by limiting the regenerated noise from the attenuator.

The pressure loss data given in this catalogue assumes that the air flow across the attenuators or splitters is laminar. Poor air inlet or discharge condition on the attenuator would incur much higher pressure drop than what is published here.

## Nomenclature

B	in mm :	Width inside the duct.
H	in mm :	Height inside the duct.
L	in mm :	Length.
d	in cm :	Splitter thickness.
s	in mm :	Airway width.
$V_{max}$	in m <sup>3</sup> /s :	Air flow rate.
$v_t$	in m/s :	Maximum face velocity = $V_{max} \div (W \times H \text{ in metres})$ .
$\Delta p$	in Pa :	Pressure loss.
$f_m$	in Hz :	Octave centre frequency.
$D_e$	in dB :	Insertion loss.
NC	:	Noise criteria.

**Table 3:** Recommended Design Noise Criteria in accordance to the CIBSE Guide A

Type of ventilated space	Design NC Level
Live theatres (< 500 seats), auditoriums, television studios, large conference and lecture rooms (> 50 people).	25
Board rooms, top management offices, conference and lecture rooms (20 – 50 people), multi-purpose halls, libraries, bedrooms in hotels, banqueting rooms, operating theatres and cinemas.	30
Public rooms in hotels, ballrooms, hospital open wards, middle management and small offices, small conference and lecture rooms (< 20 people), school classrooms, small court rooms, museums, libraries banking halls, small restaurants, cocktail bars and quality shops.	35
Toilets and washrooms, large open offices, drawing offices, reception areas (offices), halls, corridors, lobbies in hotels and hospitals, laboratories, recreation rooms, post offices, large restaurants, bars and night clubs, department stores, shops, gymnasias.	40
Kitchens in hotels, hospitals, laundry rooms, computer rooms, office equipment rooms, cafeteria, canteens, supermarkets, swimming pools, large covered parking areas, bowling alleys.	45

**Table 4:** Regenerated Noise

NC Level required	Maximum Permissible Air Velocity, $V_t$ (m/s)			
	Attenuator Type			
	DS20-75	DS20-100	DS20-150	DS20-200
25	2.4	3.2	3.9	5.0
30	3.2	4.2	5.5	6.2
35	3.8	5.0	6.7	7.4
40	4.6	5.7	7.7	8.9
45	5.4	6.6	8.6	10.4
50	6.2	7.6	9.7	11.6

**Note:** This data is incorporated into aerodynamic data in tables 9 to 12.

## NOTES:

1. The noise level in an enclosed space can be affected by the regenerated noise from the attenuator. Hence, it is recommended that to maintain the required noise level in the room, the maximum permissible air velocity in the ductwork just before the attenuator should NOT be exceeded as shown in Table 4.
2. If the attenuator is connected to a system with less than three air outlets or has a duct length which is less than 5 m, select the attenuator at 5 NC below the specified or design NC level.
3. For a system design of NC 30 or below, the selection should always be checked by an Acoustic Consultant.

# Attenuator Quick Selection Method

The selection method given in Table 5 on this page is meant to assist the design engineer to carry out a quick selection for the attenuators at preliminary design stage based on the design Noise Criteria of NC 40. This method should only be used when the required insertion loss has not been determined.

For example, if the design flow rate is 3.0 m<sup>3</sup>/s and the maximum permissible pressure drop across the attenuator is 80 Pa with a room design NC of 40, DS20-150 for a duct size of 700 mm (B) by 600 mm (H) from Table 7 will meet the requirement.

To maintain a Noise Criteria of NC 40 in the occupied space, it is advisable that the air velocity in the main duct, branch duct and final duct connection should not exceed 9.0, 7.0 and 5.0 m/s respectively.

For detail selection, please contact TROX Technical Department for assistance.

**Table 5:** Quick Selection Method

Step	Description
1	Refer to tables 6 to 9 below to select an attenuator based on the permissible static pressure across the attenuator and duct size based on NC40.
2	Then use Table 4 to check for the recommended maximum attenuator face velocity to meet NC 40.
3	Select a cross-section area for the attenuator to suit the required flow rate and to satisfy the maximum desirable face velocity and pressure drop.
4	Refer to Table 10 for the anticipated insertion loss.

**Table 6:** Aerodynamic data for DS20-200 at 600 mm long for NC35 and NC40.

W	H	Vmax For NC35		Vmax For NC40	
		Flow Rate (m <sup>3</sup> /s)	ΔP (Pa)	Flow Rate (m <sup>3</sup> /s)	ΔP (Pa)
400 (1 module)	100	0.30	52	0.36	75
	200	0.59	45	0.71	66
	300	0.89	44	1.07	64
	400	1.18	43	1.42	62
800 (2 modules)	200	1.18	45	1.42	66
	400	2.37	43	2.85	62
	600	3.55	42	4.27	61
	800	4.74	42	5.70	60
1200 (3 modules)	400	3.55	43	4.27	62
	600	5.33	42	6.41	61
	800	7.10	42	8.54	60
	1000	8.88	41	10.68	60
1600 (4 modules)	1200	10.66	41	12.82	60
	400	4.74	43	5.70	62
	600	7.10	42	8.54	61
	800	9.47	42	11.39	60
	1000	11.84	41	14.24	60
2000 (5 modules)	1200	14.21	41	17.09	60
	400	5.92	43	7.12	62
	600	8.88	42	10.68	61
	800	11.84	42	14.24	60
	1000	14.80	41	17.80	60
	1200	17.76	41	21.36	60



# Quick Selection Method

**Table 7:** Aerodynamic data for DS20-150 at 600 mm long for NC35 and NC40

W	H	Vmax For NC35		Vmax For NC40	
		Flow Rate (m³/s)	ΔP (Pa)	Flow Rate (m³/s)	ΔP (Pa)
350 (1 module)	100	0.23	64	0.27	88
	200	0.47	61	0.54	81
	300	0.70	59	0.81	78
700 (2 modules)	200	0.94	61	1.08	81
	400	1.88	58	2.16	77
	600	2.81	57	3.23	75
1050 (3 modules)	300	2.11	59	2.43	78
	600	4.22	57	4.85	76
	900	6.33	57	7.28	75
1400 (4 modules)	300	2.81	59	3.23	78
	600	5.63	57	6.47	76
	900	8.44	57	9.70	75
	1200	11.26	56	12.94	74
1750 (5 modules)	300	3.52	59	4.04	78
	600	7.04	57	8.09	76
	900	10.55	57	12.13	75
	1200	14.07	56	16.17	74
	1500	17.59	56	20.21	74

**Table 8:** Aerodynamic data for DS20-100 at 600 mm long for NC35 and NC 40

W	H	Vmax For NC35		Vmax For NC40	
		Flow Rate (m³/s)	ΔP (Pa)	Flow Rate (m³/s)	ΔP (Pa)
300 (1 module)	100	0.15	81	0.17	104
	200	0.30	76	0.34	97
	300	0.45	74	0.51	95
600 (2 modules)	200	0.60	76	0.68	97
	400	1.20	73	1.37	95
	600	1.80	72	2.05	94
900 (3 modules)	300	1.35	74	1.54	96
	600	2.70	72	3.08	94
	900	4.05	72	4.62	93
1200 (4 modules)	300	1.80	74	2.05	96
	600	3.60	72	4.10	94
	900	5.40	72	6.16	93
	1200	7.20	71	8.21	93
1500 (5 modules)	300	2.25	74	2.57	97
	600	4.50	72	5.13	94
	900	6.75	72	7.70	93
	1200	9.00	71	10.26	93
	1500	11.25	71	12.83	93

# Quick Selection Method

**Table 9:** Aerodynamic data for DS20-75 at 600 mm long for NC35 and NC40

W	H	Vmax For NC35		Vmax For NC40	
		Flow Rate (m³/s)	ΔP (Pa)	Flow Rate (m³/s)	ΔP (Pa)
275 (1 module)	100	0.10	88	0.13	136
	200	0.21	84	0.25	119
550 (2 modules)	200	0.42	84	0.51	124
	300	0.63	82	0.76	120
	400	0.84	81	1.01	118
	500	1.05	81	1.27	118
825 (3 modules)	300	0.94	81	1.14	120
	400	1.25	80	1.52	119
	500	1.57	80	1.90	118
	600	1.88	80	2.28	117
1100 (4 modules)	300	1.25	81	1.52	120
	500	2.09	80	2.53	119
	700	2.93	80	3.54	118
	900	3.76	79	4.55	117
1375 (5 modules)	400	2.09	81	2.53	118
	600	3.14	80	3.80	117
	800	4.18	80	5.06	117
	1000	5.23	79	6.33	116
	1200	6.27	79	7.59	116

**Table 10:** Insert Loss for 600 mm long DS20 attenuator

Product Type @ 600 mm long	Insert Loss, De (in dB) at Octave Band Freq. (Hz)					
	125	250	500	1000	2000	4000
DS20-200	3	8	16	18	13	8
DS20-150	3	9	20	23	17	11
DS20-100	4	11	25	31	22	15
DS20-75	5	12	29	36	26	18

**Notes:**

The data given in the table below should NOT be used if Melinex faced attenuators are required because Melinex will affect the acoustic performance of the attenuator. In such case, please contact TROX for attenuator selection.

# Attenuator Full Selection Method

## For full selection:

TROX will need the following information from the design consultant to select the attenuator;

1. The design insertion losses (IL) at each octave band frequency, ranging from 63 Hz up to 8000 Hz. **NOTE:** If this information is NOT available, then TROX will need the fan sound power spectrum and the design noise criteria (NC). Under this condition, TROX will make certain assumptions when selecting the attenuators. Please note that the selection made by TROX must be checked and approved by the design consultant in the absence of the required/specified IL. As an equipment manufacturer, TROX is NOT responsible for the system design.
2. The design airflow rate through each silencer with the maximum permissible pressure drop across each silencer.
3. Duct connection size, and the maximum permissible length for the silencer if applicable. Please note that TROX standard silencer lengths are 600; 900; 1200; 1500; 1800 and 2100 mm long. TROX standard lengths should be used at all times.

The same applies for Type 'DK' splitters if splitters are required in builder's work shaft or ducting.

# Order Details

## Order Details

### General Specifications – For Type ‘DS’ Rectangular Cased Attenuators

The in-line rectangular attenuator is fitted with Type ‘DK’ Splitters. The in-fill noise absorption material is classified as a Class ‘O’ material under the UK’s Building Regulation, which is fire retardant.

The casing construction complies with UK’s ductwork specification, DW 144 for Class B. As a standard supply, the attenuator will be fitted with 40 mm Doby slide on flange.

### General Specifications – For Type ‘DK’ Splitters only.

This aerodynamically shaped splitter is made from 1 mm thk galvanised sheet steel. The exposed surface of the in-fill noise absorption material has a tissue lining to prevent fibre erosion and is further protected by an expanded metal sheet. Installation of splitters at site to be carried out by others.

### Order Code for Rectangular Attenuators

DS / 0 / 20 - 100 / 0 / 1200 x 900 x 900

Attenuator Type

Type Suffix:  
0 – Vertical airways  
(Standard supply).

L – ‘Evase fairing’ for low ΔP  
Z – Horizontal airways.  
H – High pressure casings  
M – Melinex infill cover  
B – Vertical bend.  
BZ – Horizontal bend.  
R – RSA flange connections

Splitter thickness in ‘cm’

Airway width in mm  
(Max. 200 mm)

Unit overall dimension:

Width x Height x Length  
In mm.

Material:

0 – galvanized steel  
(Standard supply).  
304 - Grade 304 stainless steel.  
316 - Grade 316 stainless steel.

### Order Examples:

1. DS/HM/20-200/0/ 1200 x 600 x 1500; 2 nos.
2. DS/0/20-150/0/ 700 x 400 x 900; 4 nos.

### Order Code for Splitters only

DK / ZM / 20 - 100 / 304 / 800 x 800 x 1200

Splitter Type

Type Suffix:  
0 – Vertical airways  
(Standard supply).

Z – Horizontal airways.  
H – High pressure casings  
M – Melinex infill cover

Splitter width (mm)

Airway width (mm)

Unit overall dimension:

Width x Height x Length  
In mm.

Material:

0 – galvanized steel  
(Standard supply).  
304 - Grade 304 stainless steel.  
316 - Grade 316 stainless steel.